



Figura 1 – Veículo I-2



Figura 2 – Carregamento do veículo I-2



Figura 3 – Linha de influência para o momento fletor veículo I-2

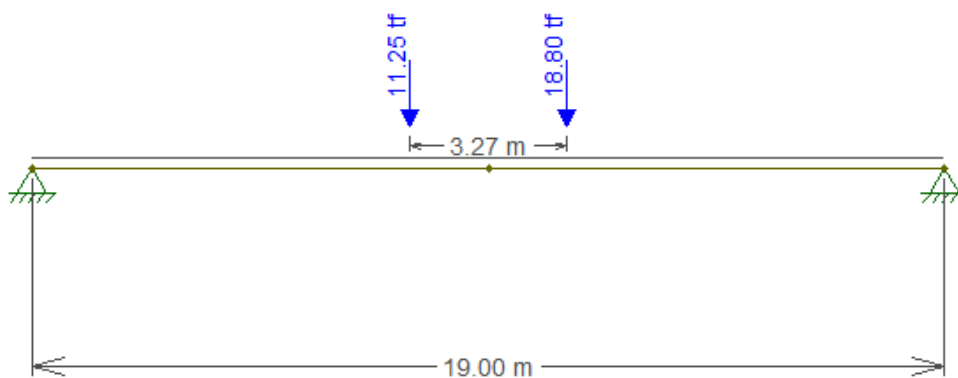

Figura 4 – Envoltória de momento fletor veículo I-2

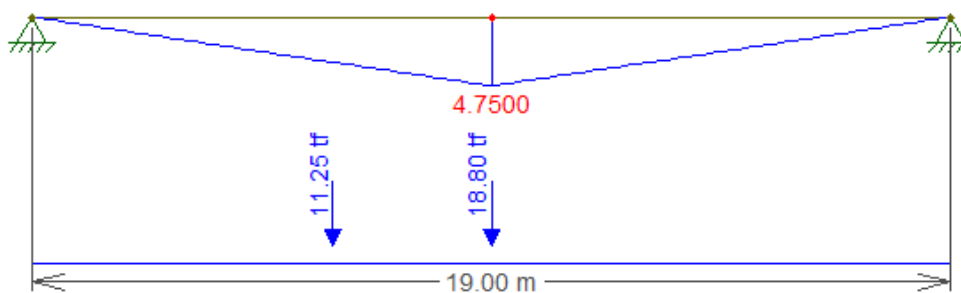

Figura 5 – Veículo I-2A

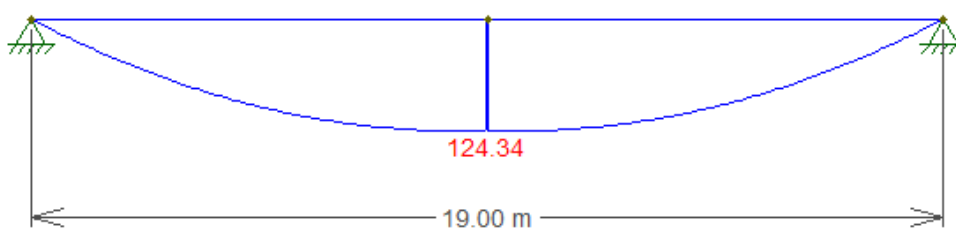

Figura 6 – Carregamento do veículo I-2A



Figura 7 – Linha de influência para o momento fletor veículo I-2A

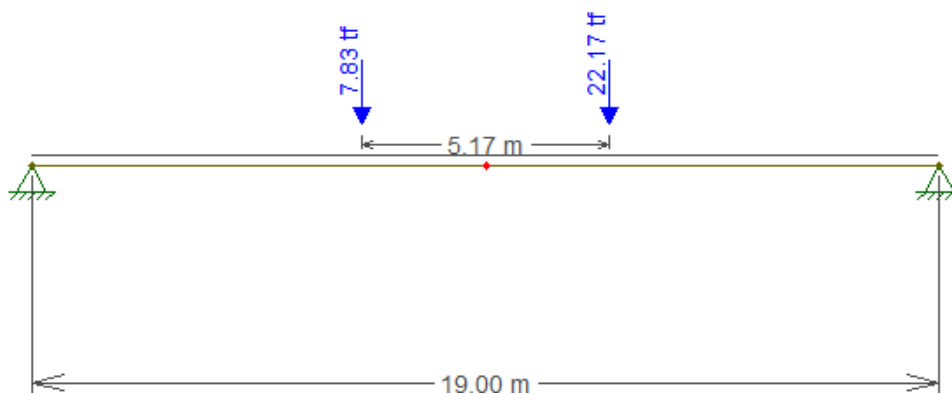

Figura 8 – Envoltória de momento fletor veículo I-2A

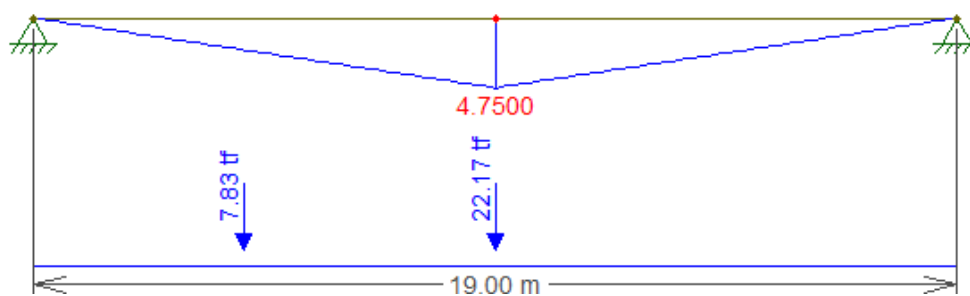

Figura 9 – Veículo I-3

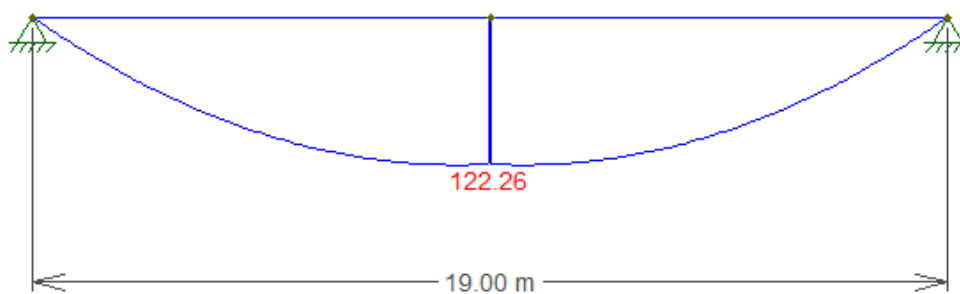

Figura 10 – Carregamento do veículo I-3



Figura 11 – Linha de influência para o momento fletor veículo I-3

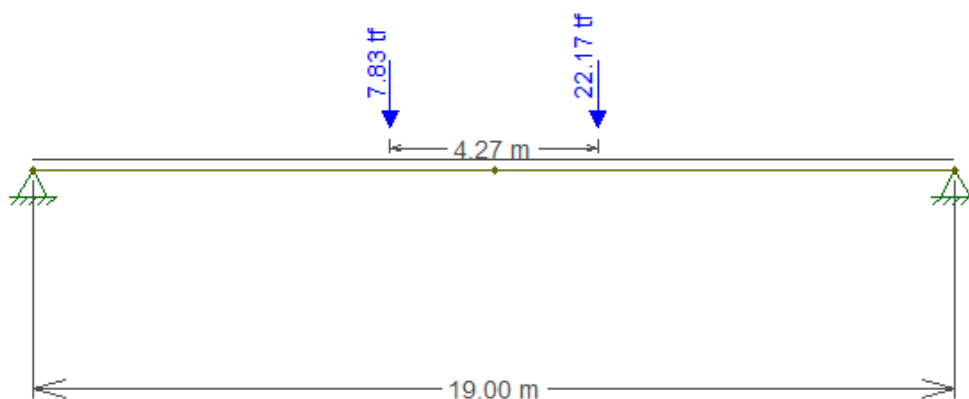

Figura 12 – Envoltória de momento fletor veículo I-3

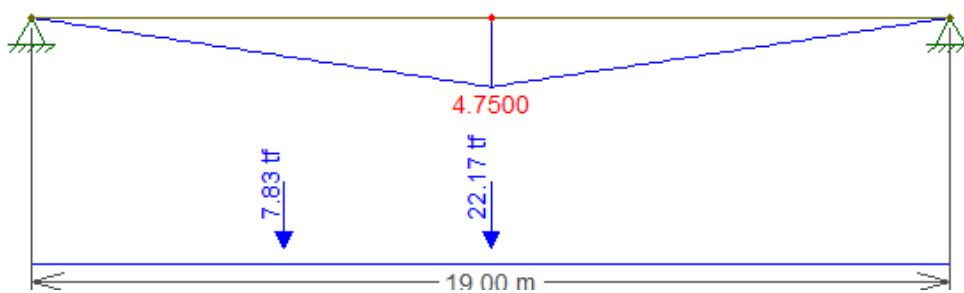

Figura 13 – Veículo I-3A

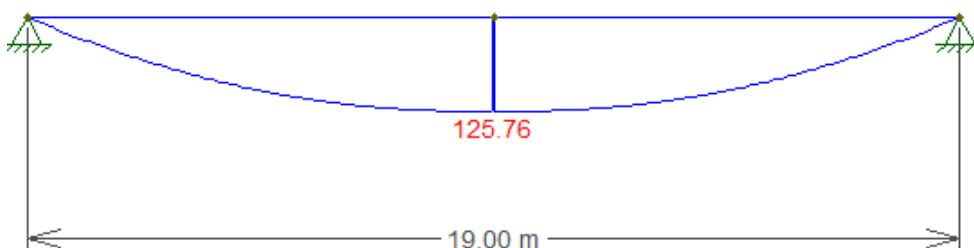

Figura 14 – Carregamento do veículo I-3A



Figura 15 – Linha de influência para o momento fletor veículo I-3A

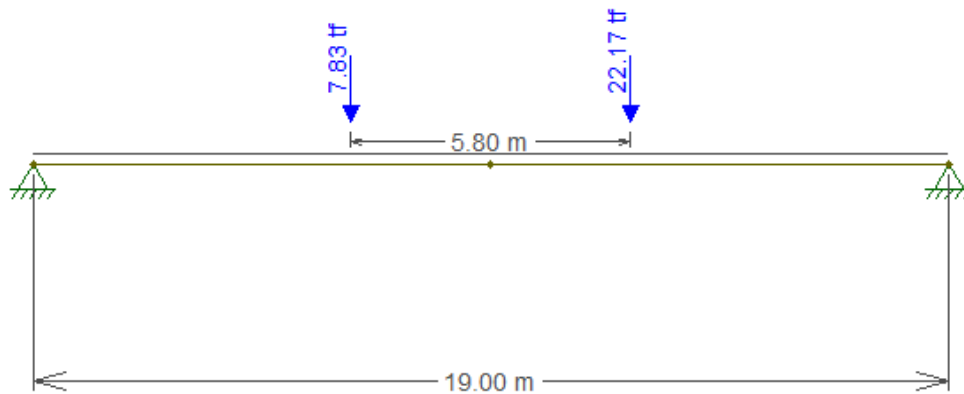

Figura 16 – Envoltória de momento fletor veículo I-3A

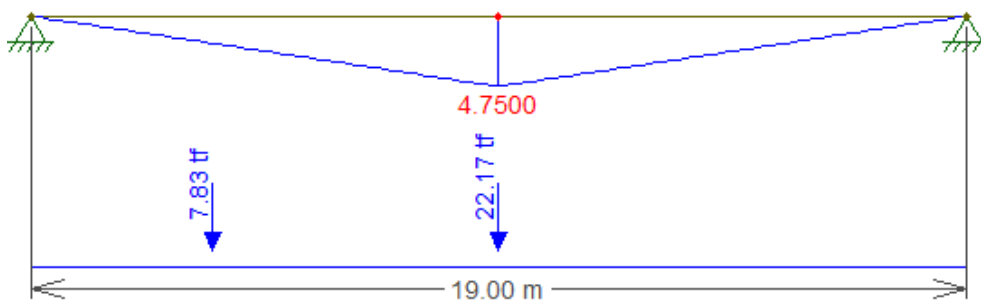

Figura 17 – Veículo I-6

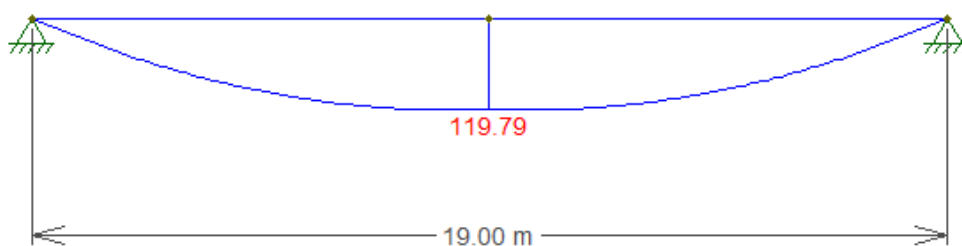

Figura 18 – Carregamento do veículo I-6



Figura 19 – Linha de influência para o momento fletor veículo I-6

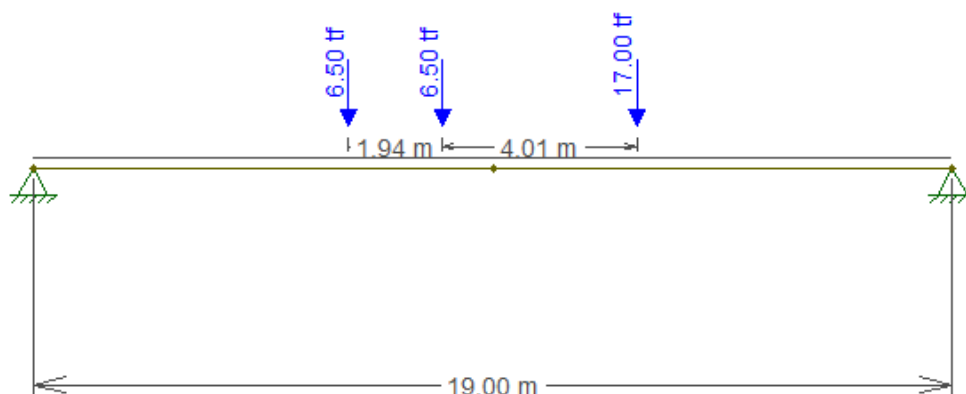

Figura 20 – Envoltória de momento fletor veículo I-6

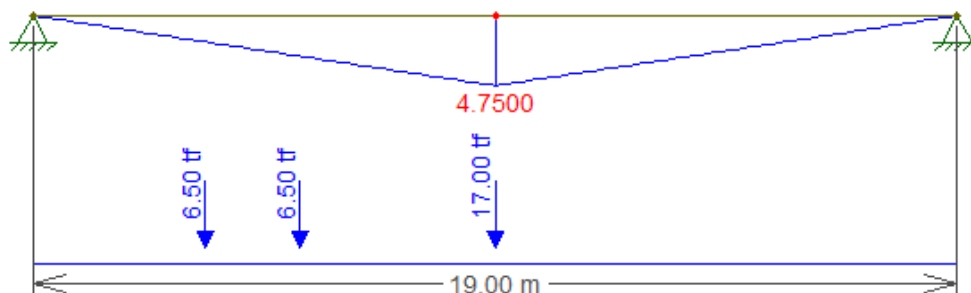

Figura 21 – Veículo I-6A

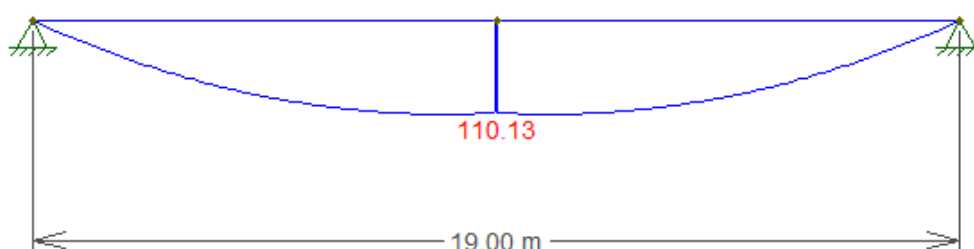

Figura 22 – Carregamento do veículo I-6A



Figura 23 – Linha de influência para o momento fletor veículo I-6A

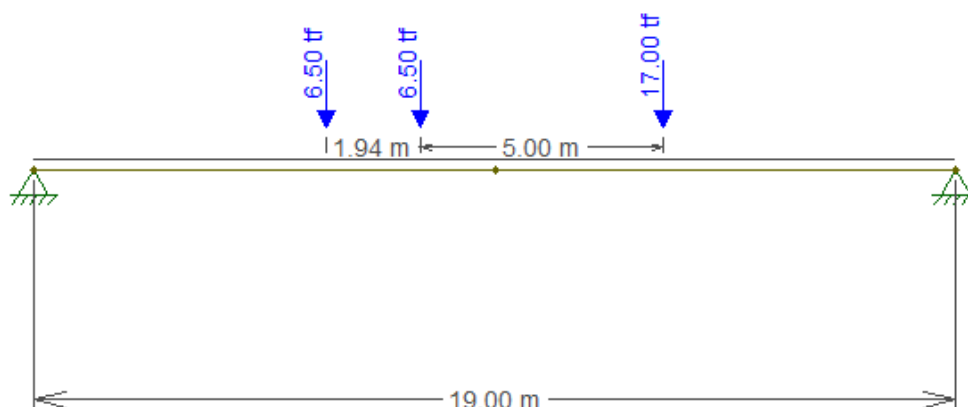

Figura 24 – Envoltória de momento fletor veículo I-6A

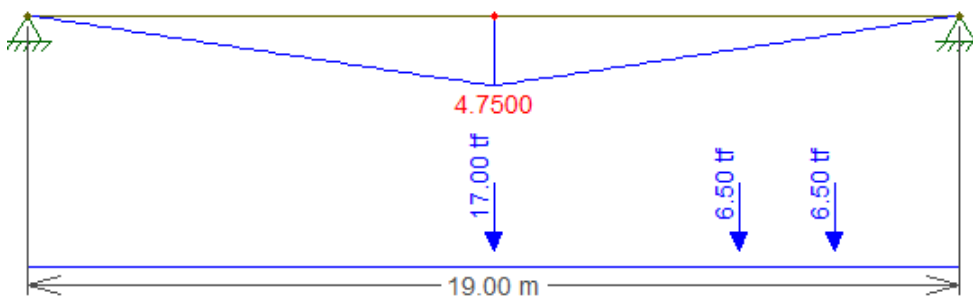

Figura 25 – Veículo I-9A

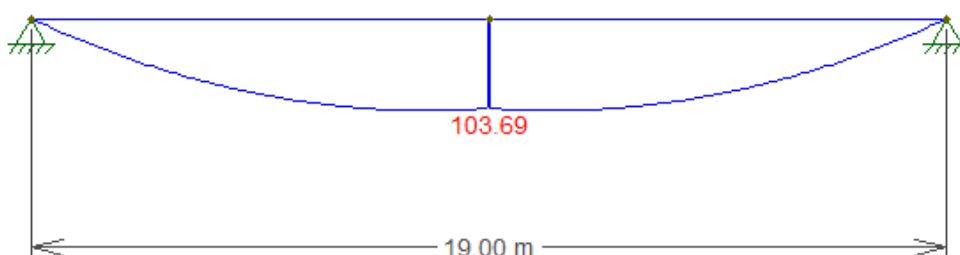

Figura 26 – Carregamento do veículo I-9A



Figura 27 – Linha de influência para o momento fletor veículo I-9A

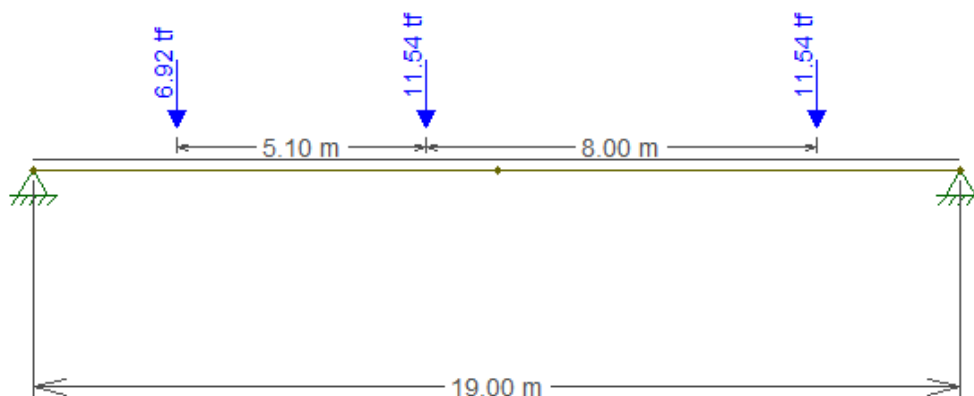

Figura 28 – Envoltória de momento fletor veículo I-9A

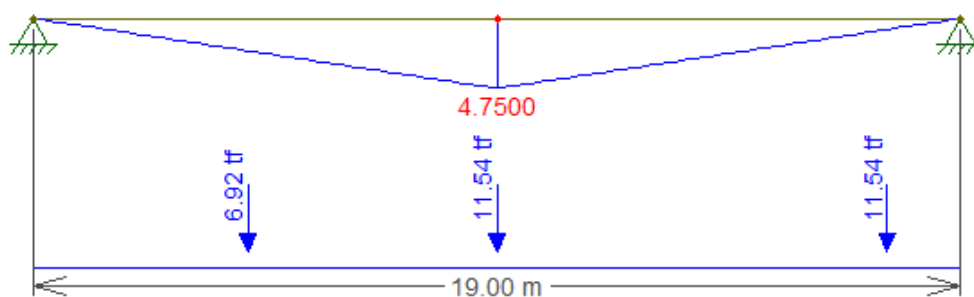

Figura 29 – Veículo I-10

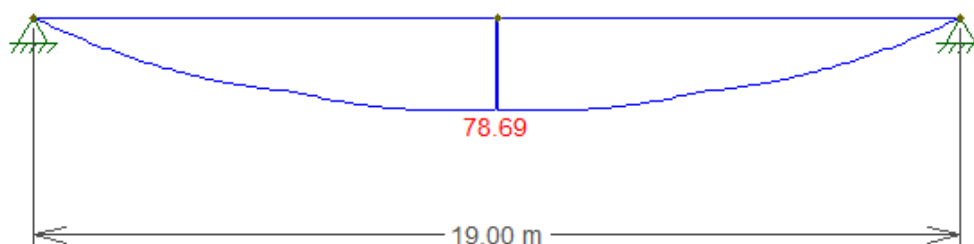

Figura 30 – Carregamento do veículo I-10



Figura 31 – Linha de influência para o momento fletor veículo I-10

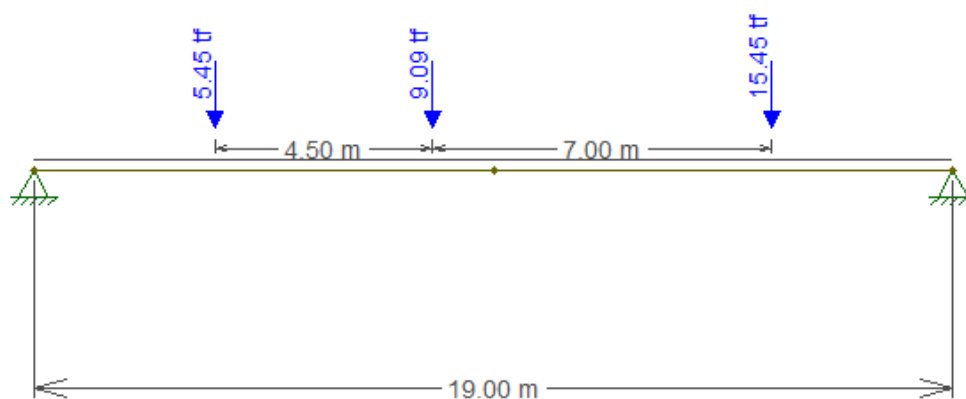

Figura 32 – Envoltória de momento fletor veículo I-10

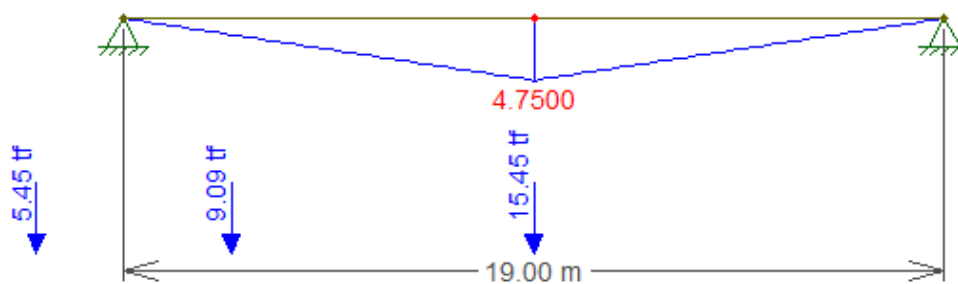

Figura 33 – Veículo I-10A

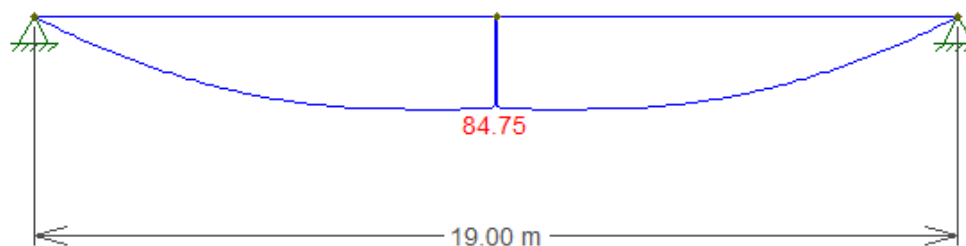

Figura 34 – Carregamento do veículo I-10A



Figura 35 – Linha de influência para o momento fletor veículo I-10A

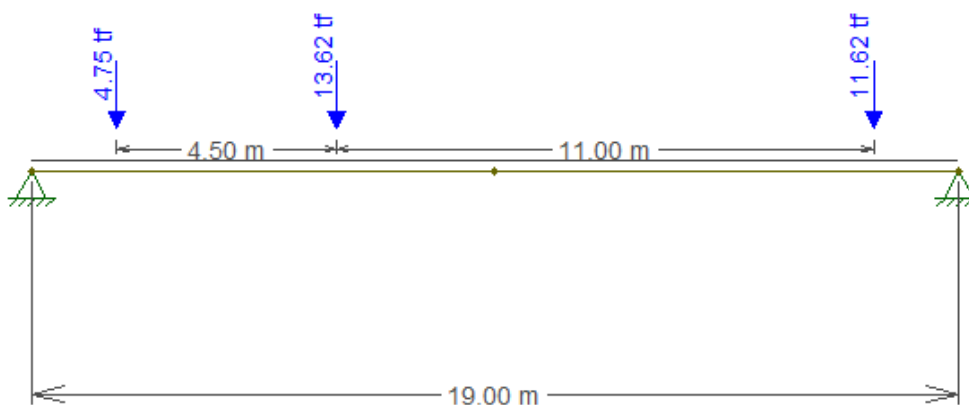

Figura 36 – Envoltória de momento fletor veículo I-10A

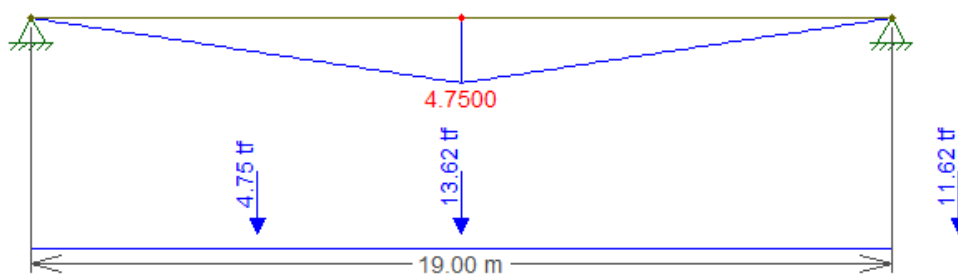

Figura 37 – Veículo I-11

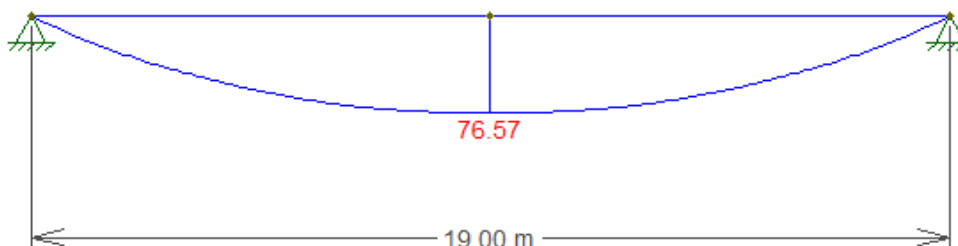

Figura 38 – Carregamento do veículo I-11



Figura 39 – Linha de influência para o momento fletor veículo I-11

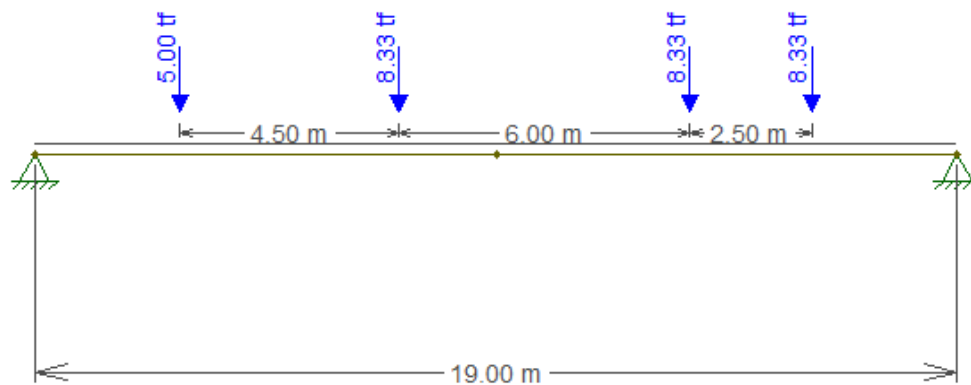

Figura 40 – Envoltória de momento fletor veículo I-11

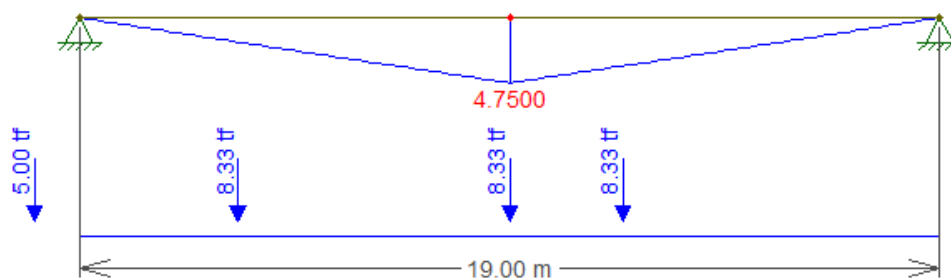

Figura 41 – Veículo I-12

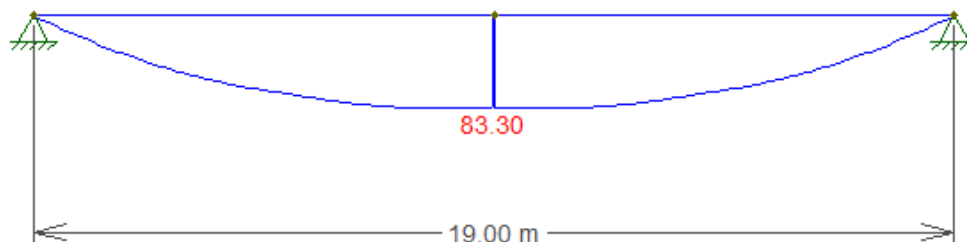

Figura 42 – Carregamento do veículo I-12



Figura 43 – Linha de influência para o momento fletor veículo I-12

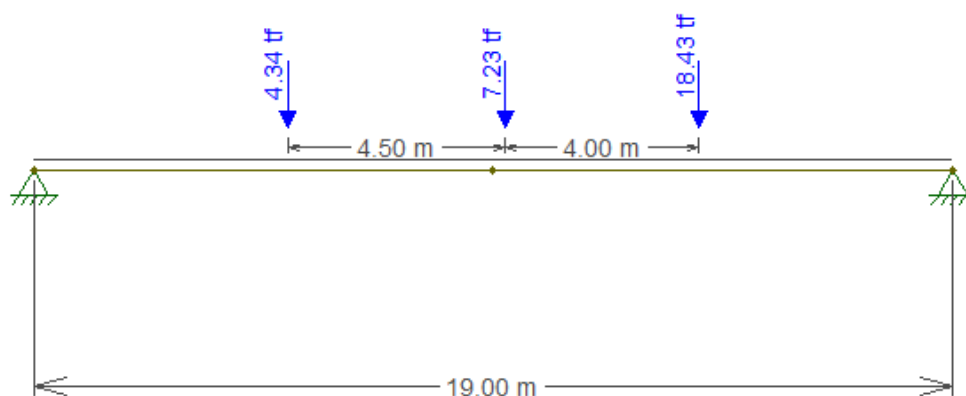

Figura 44 – Envoltória de momento fletor veículo I-12

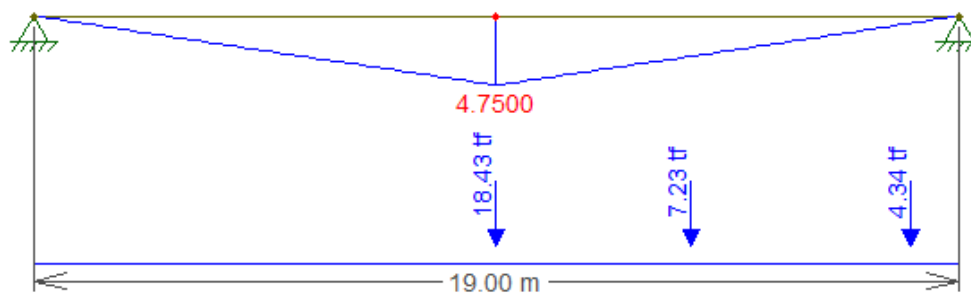

Figura 45 – Veículo I-12A

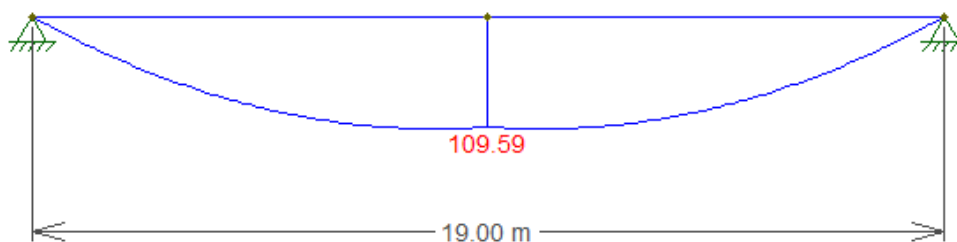

Figura 46 – Carregamento do veículo I-12A



Figura 47 – Linha de influência para o momento fletor veículo I-12A

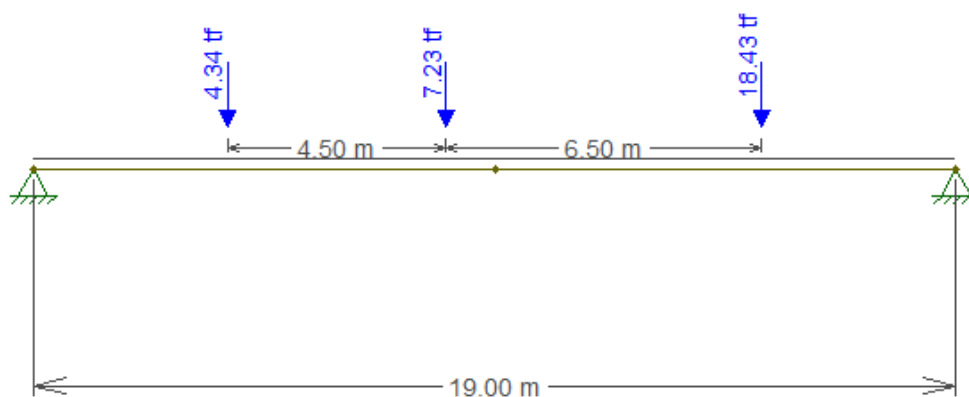

Figura 48 – Envoltória de momento fletor veículo I-12A

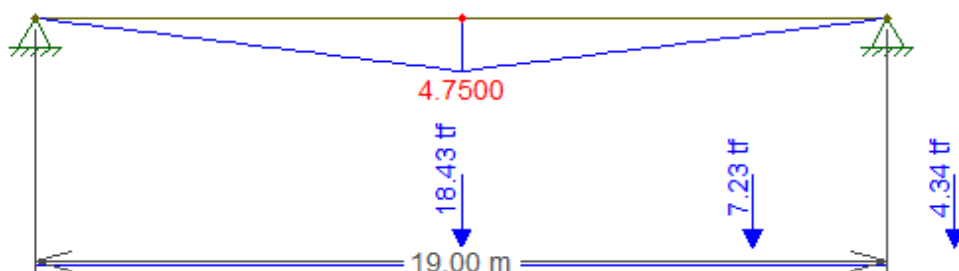

Figura 49 – Veículo I-13

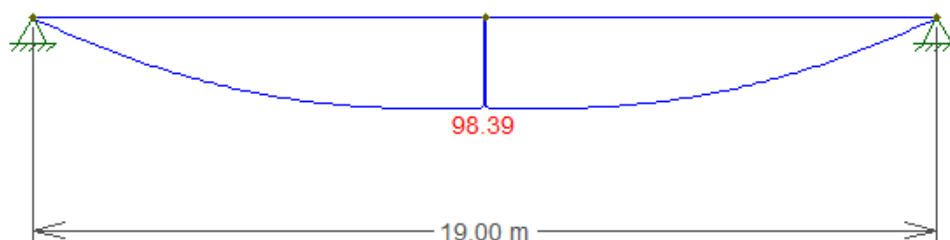

Figura 50 – Carregamento do veículo I-13



Figura 51 – Linha de influência para o momento fletor veículo I-13

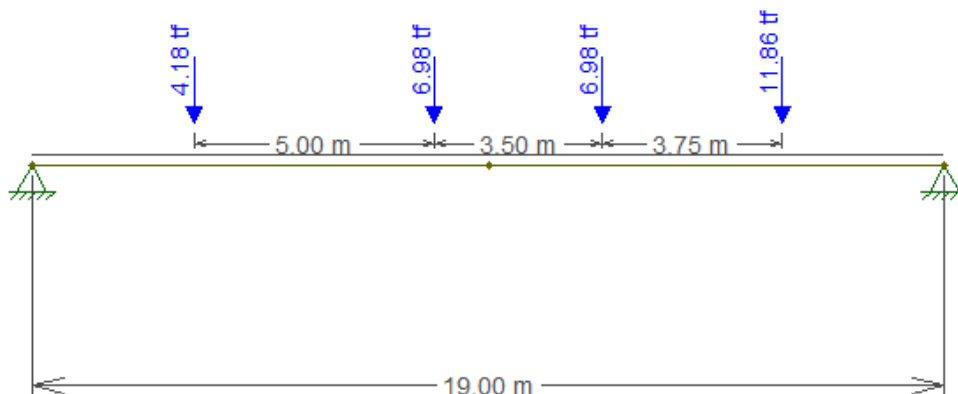

Figura 52 – Envoltória de momento fletor veículo I-13

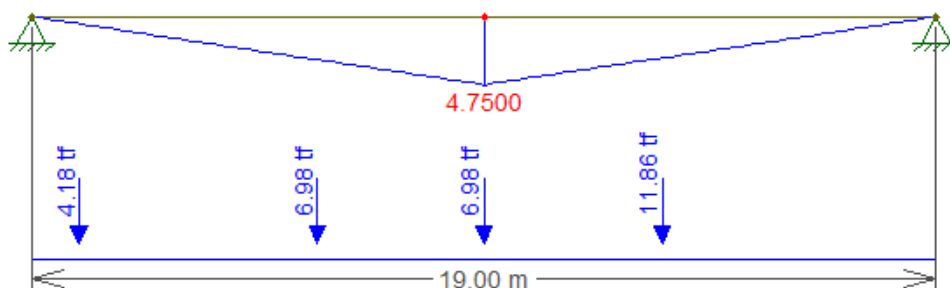

Figura 53 – Veículo I-14

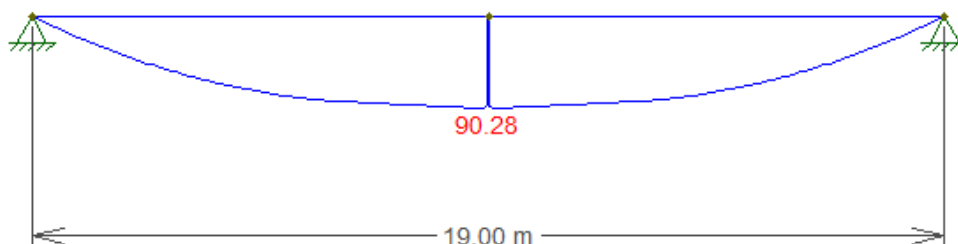

Figura 54 – Carregamento do veículo I-14



Figura 55 – Linha de influência para o momento fletor veículo I-14

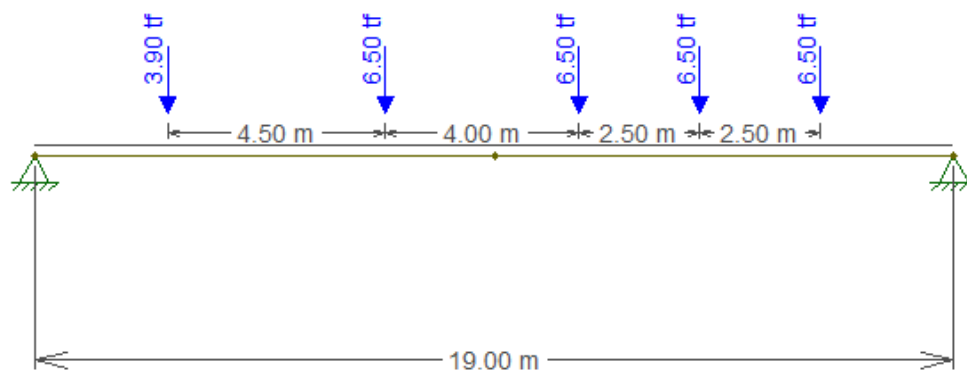

Figura 56 – Envoltória de momento fletor veículo I-14

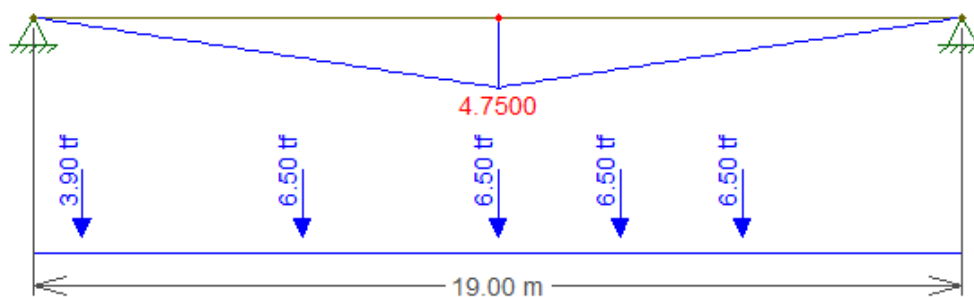

Figura 57 – Veículo I-16

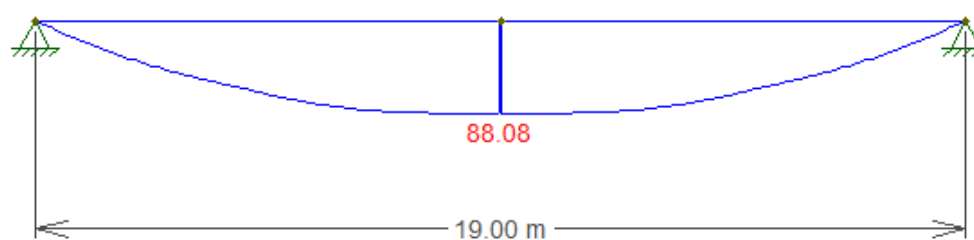

Figura 58 – Carregamento do veículo I-16



Figura 59 – Linha de influência para o momento fletor veículo I-16

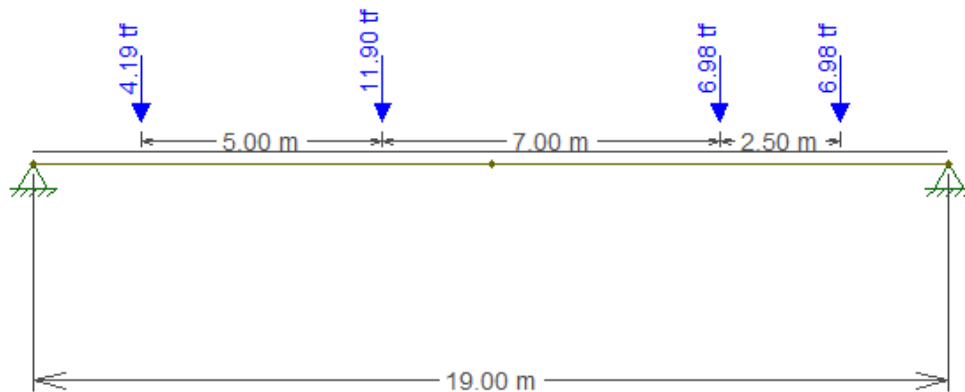

Figura 60 – Envoltória de momento fletor veículo I-16

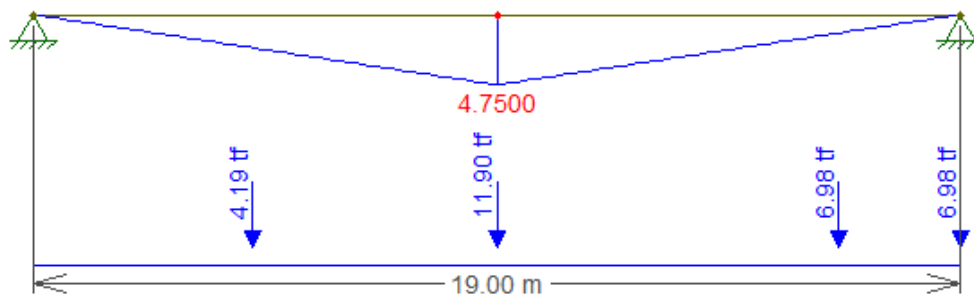

Figura 61 – Veículo I-18

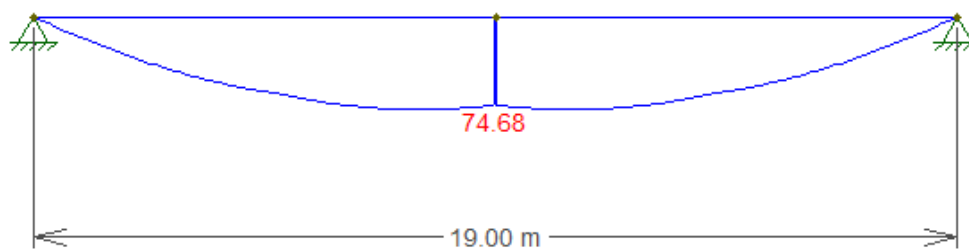

Figura 62 – Carregamento do veículo I-18



Figura 63 – Linha de influência para o momento fletor veículo I-18

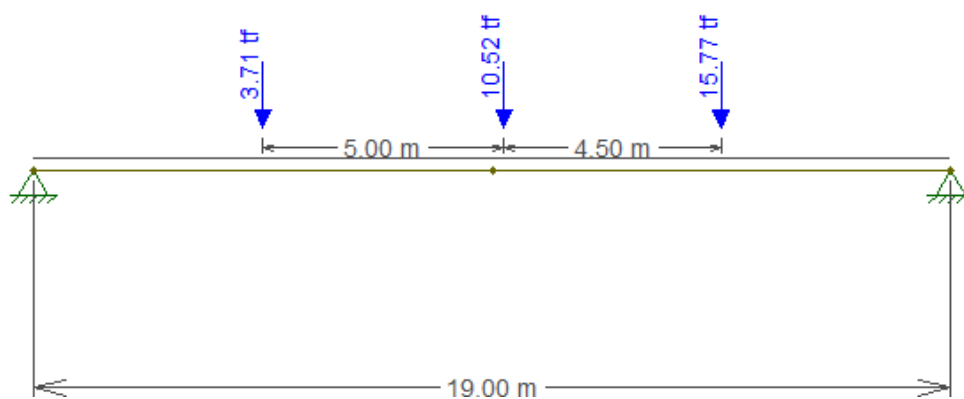

Figura 64 – Envoltória de momento fletor veículo I-18

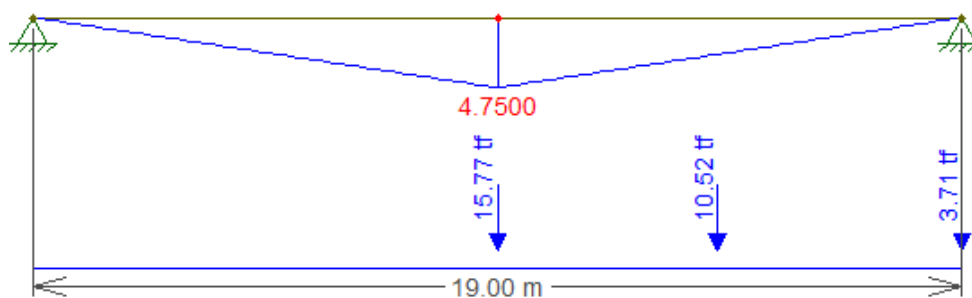

Figura 65 – Veículo I-18A

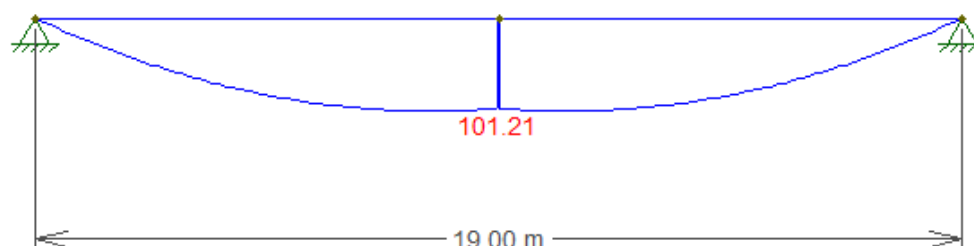

Figura 66 – Carregamento do veículo I-18A



Figura 67 – Linha de influência para o momento fletor veículo I-18A

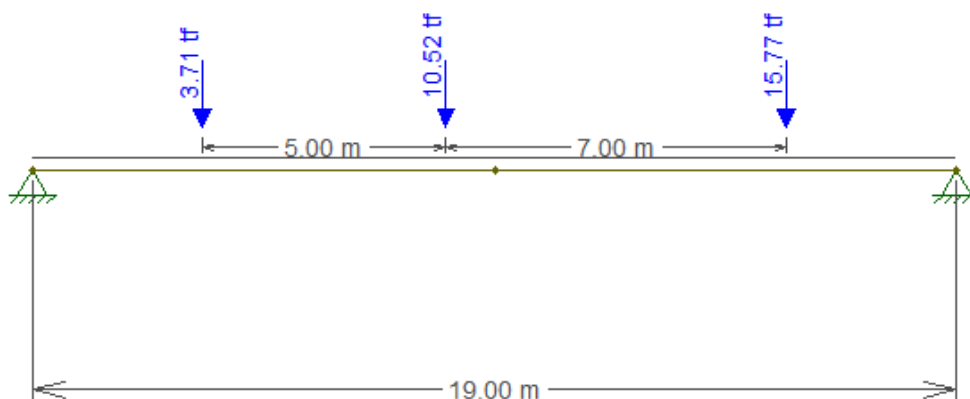

Figura 68 – Envoltória de momento fletor veículo I-18A

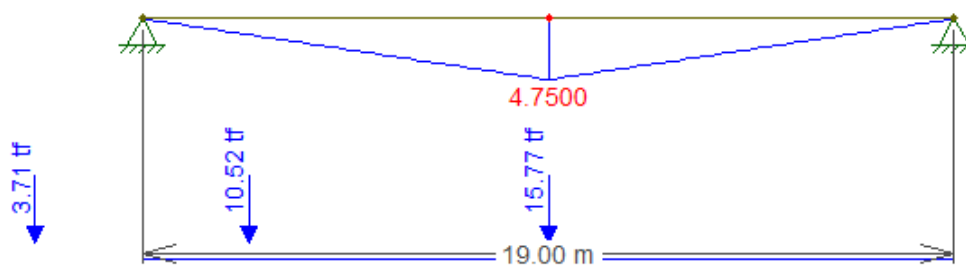

Figura 69 – Veículo I-20

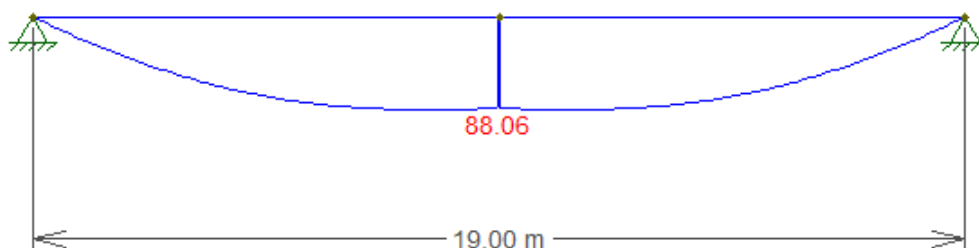

Figura 70 – Carregamento do veículo I-20



Figura 71 – Linha de influência para o momento fletor veículo I-20

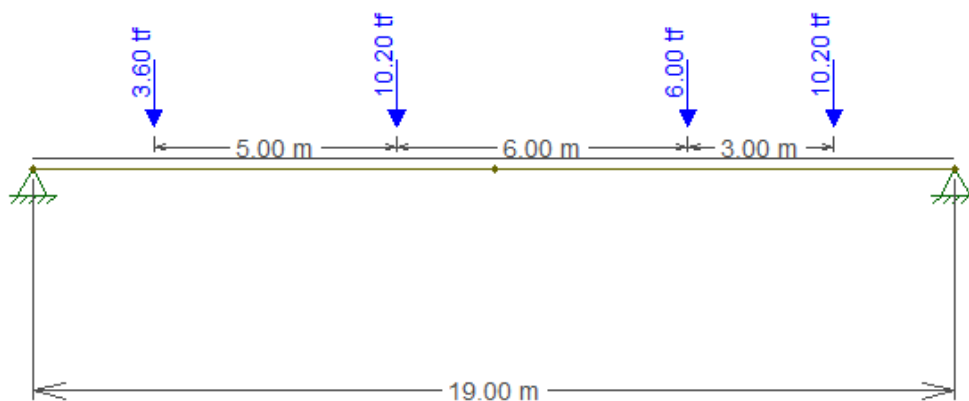

Figura 72 – Envoltória de momento fletor veículo I-20

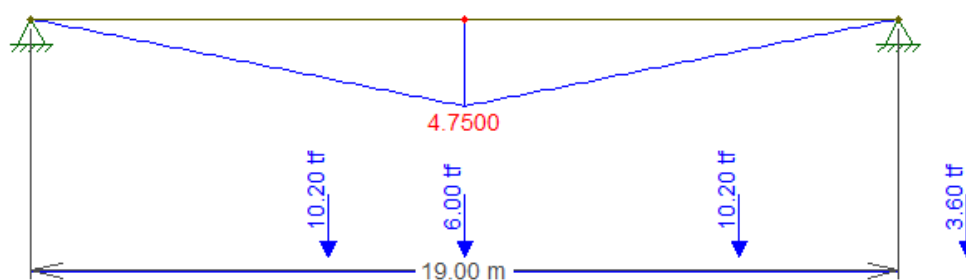

Figura 73 – Veículo I-22

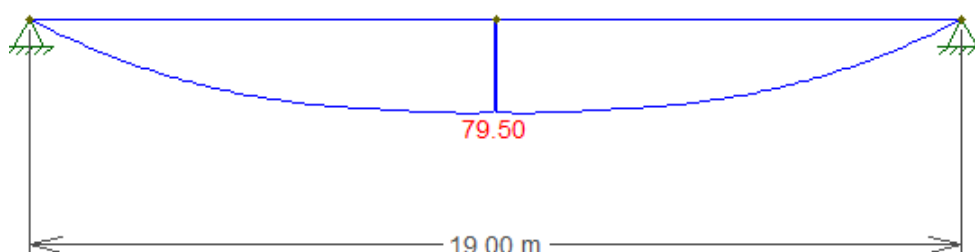

Figura 74 – Carregamento do veículo I-22



Figura 75 – Linha de influência para o momento fletor veículo I-22

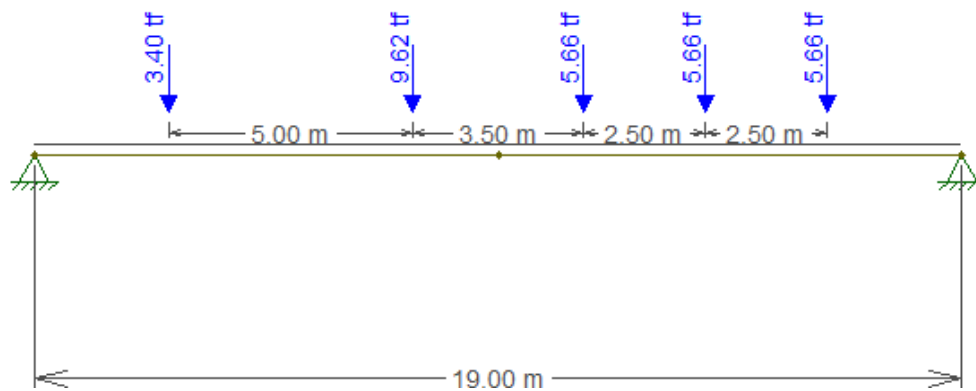

Figura 76 – Envoltória de momento fletor veículo I-22

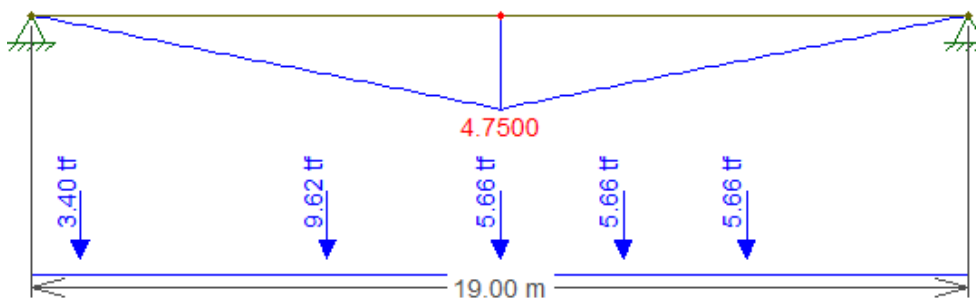

Figura 77 – Veículo I-26

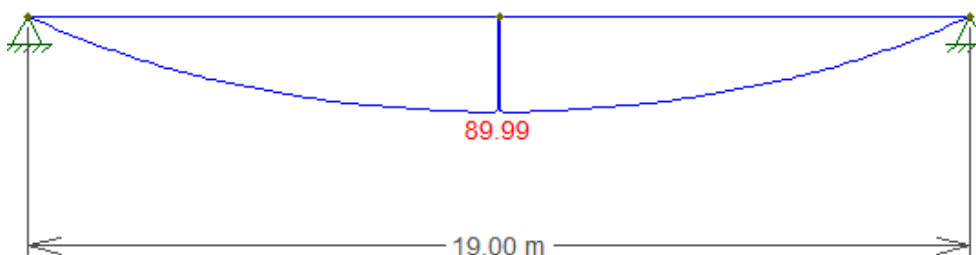

Figura 78 – Carregamento do veículo I-26



Figura 79 – Linha de influência para o momento fletor veículo I-26

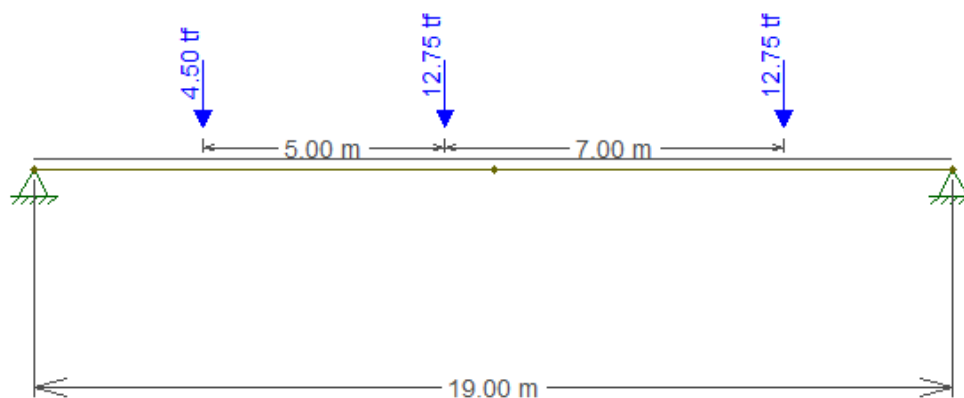

Figura 80 – Envoltória de momento fletor veículo I-26

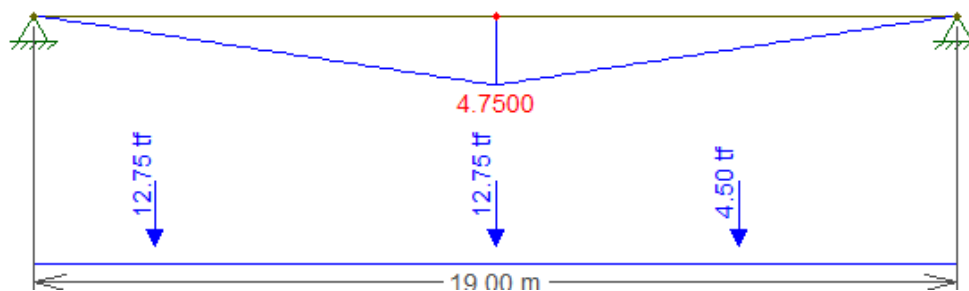

Figura 81 – Veículo I-26A

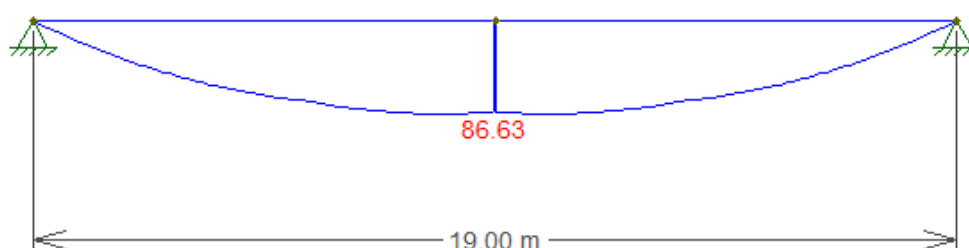

Figura 82 – Carregamento do veículo I-26A



Figura 83 – Linha de influência para o momento fletor veículo I-26A

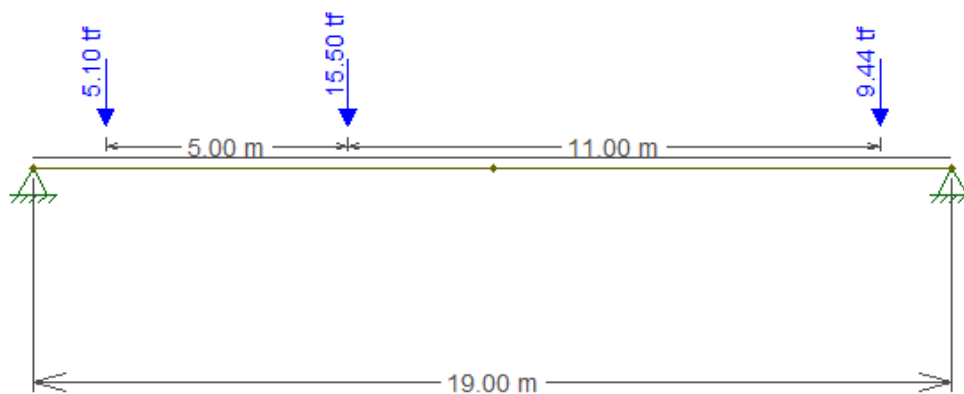

Figura 84 – Envoltória de momento fletor veículo I-26A

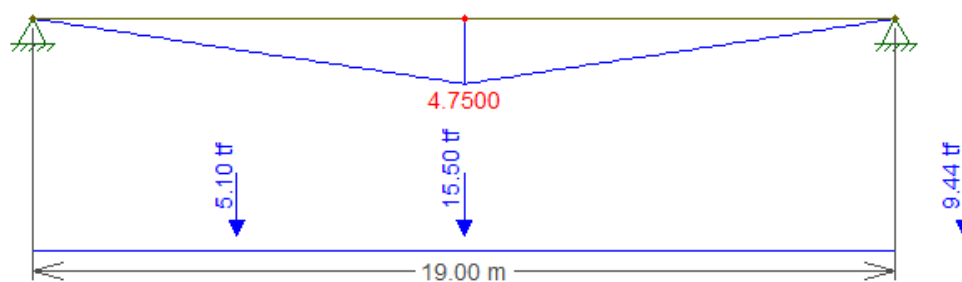

Figura 85 – Veículo I-29

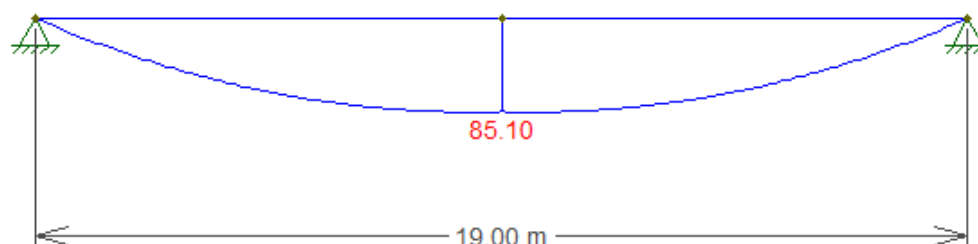

Figura 86 – Carregamento do veículo I-29



Figura 87 – Linha de influência para o momento fletor veículo I-29

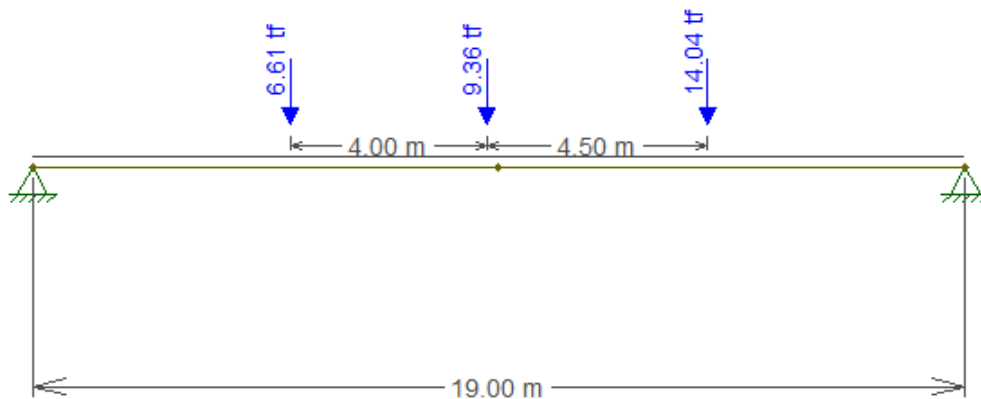

Figura 88 – Envoltória de momento fletor veículo I-29

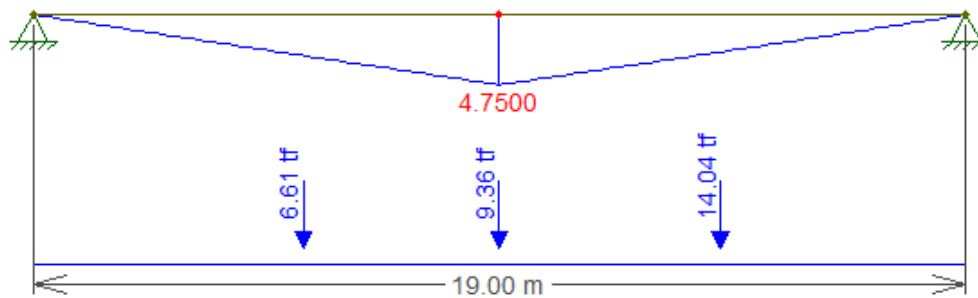

Figura 89 – Veículo I-29A

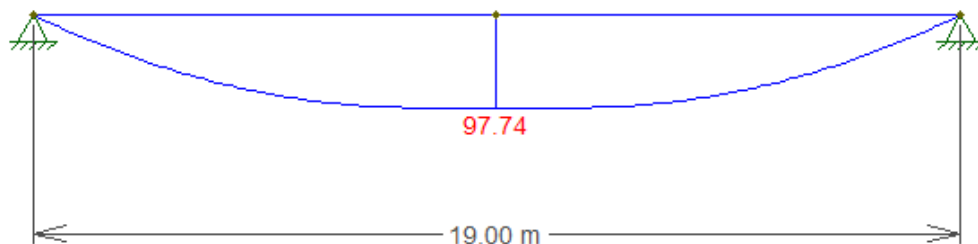

Figura 90 – Carregamento do veículo I-29A



Figura 91 – Linha de influência para o momento fletor veículo I-29A

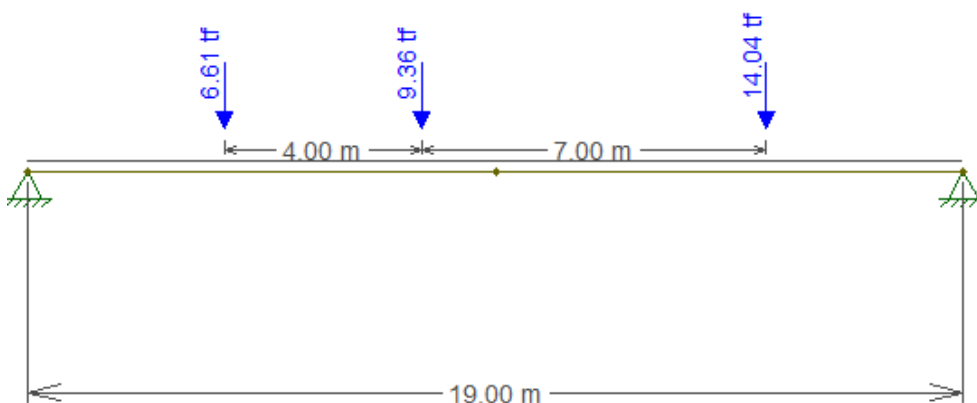

Figura 92 – Envoltória de momento fletor veículo I-29A

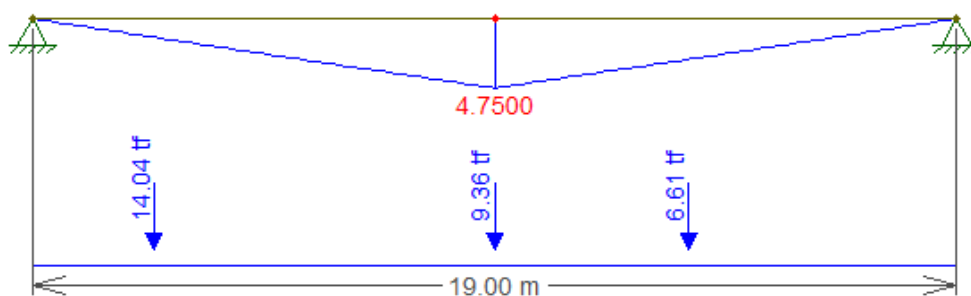

Figura 93 – Veículo I-37

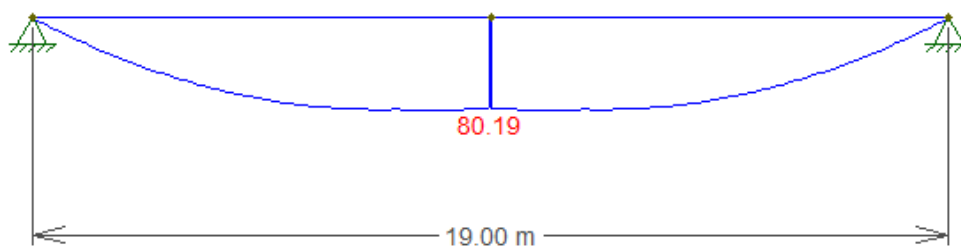

Figura 94 – Carregamento do veículo I-37



Figura 95 – Linha de influência para o momento fletor veículo I-37

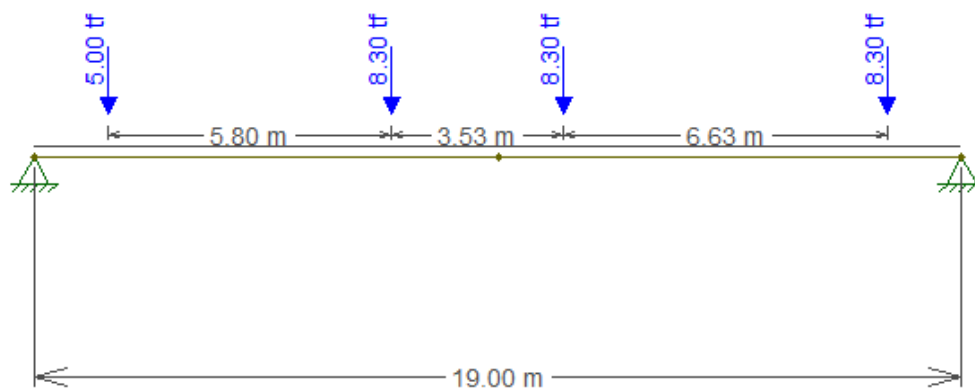

Figura 96 – Envoltória de momento fletor veículo I-37

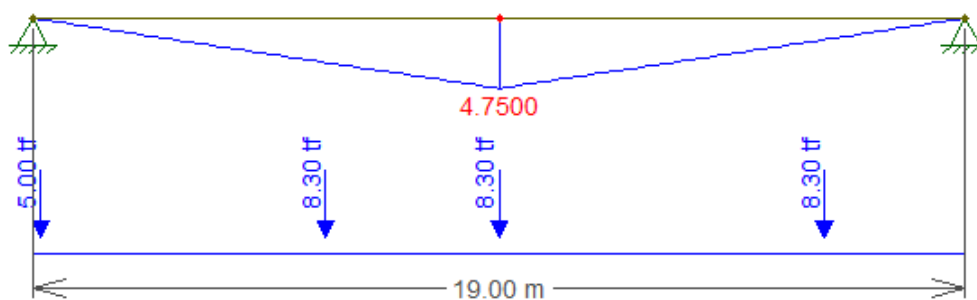

Figura 97 – Veículo I-40

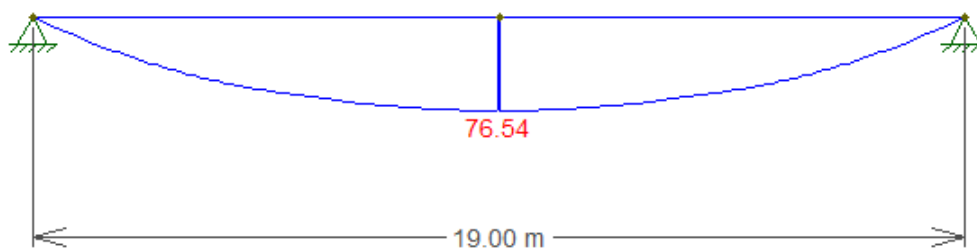

Figura 98 – Carregamento do veículo I-40



Figura 99 – Linha de influência para o momento fletor veículo I-40

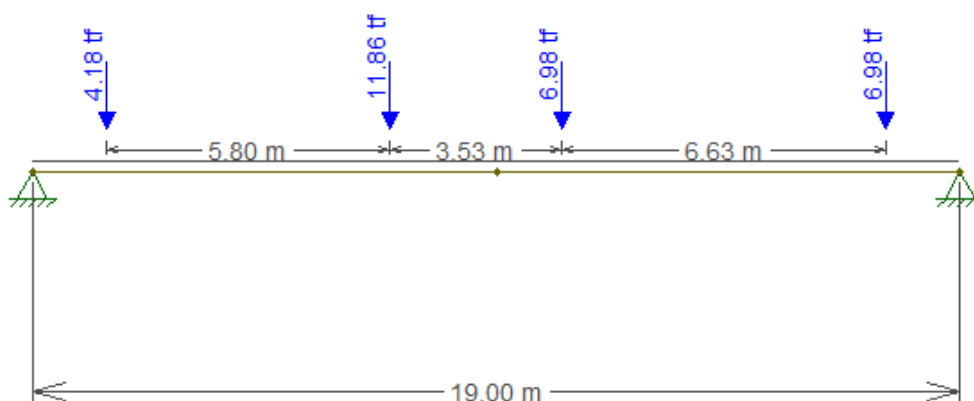

Figura 100 – Envoltória de momento fletor veículo I-40

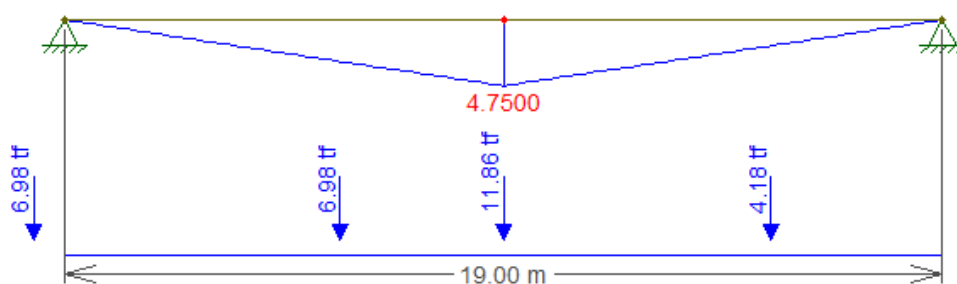

Figura 101 – Veículo I-50

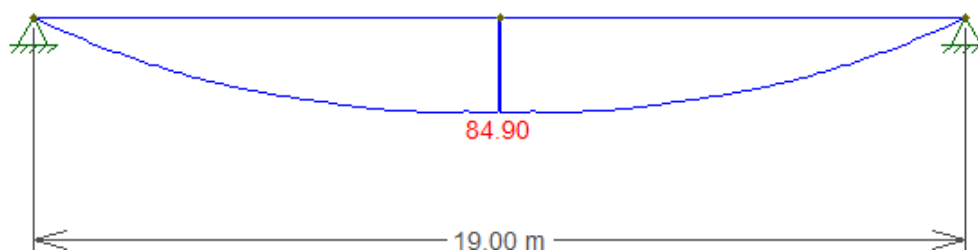

Figura 102 – Carregamento do veículo I-50



Figura 103 – Linha de influência para o momento fletor veículo I-50

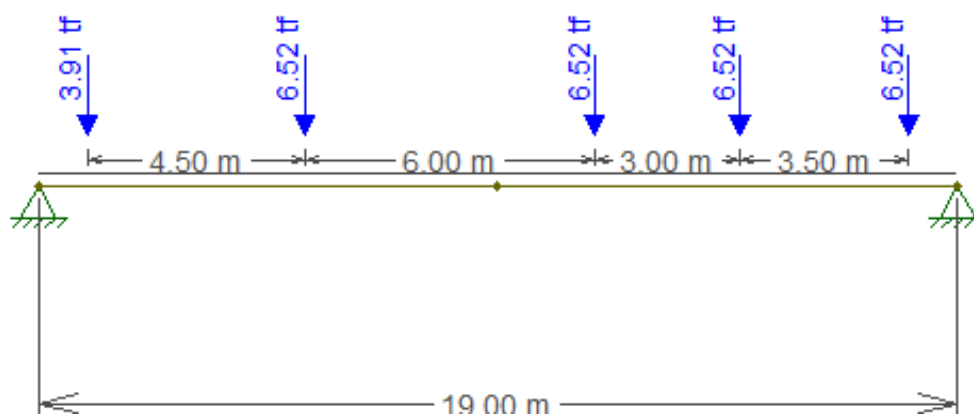

Figura 104 – Envoltória de momento fletor veículo I-50

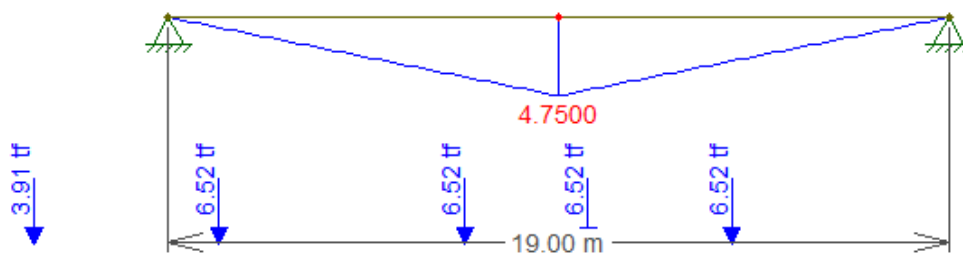

Figura 105 – Veículo I-51

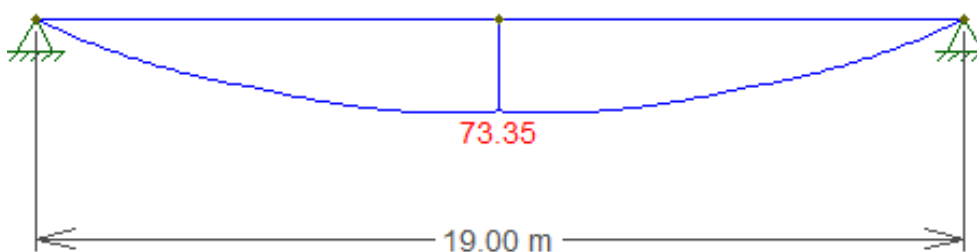

Figura 106 – Carregamento do veículo I-51



Figura 107 – Linha de influência para o momento fletor veículo I-51

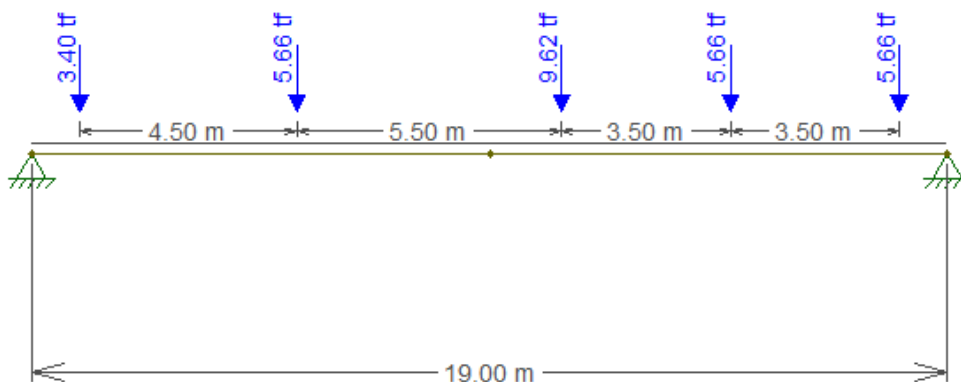

Figura 108 – Envoltória de momento fletor veículo I-51

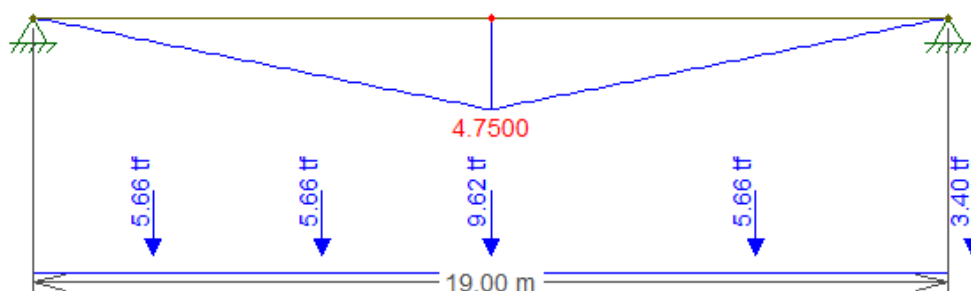

Figura 109 – Veículo I-63

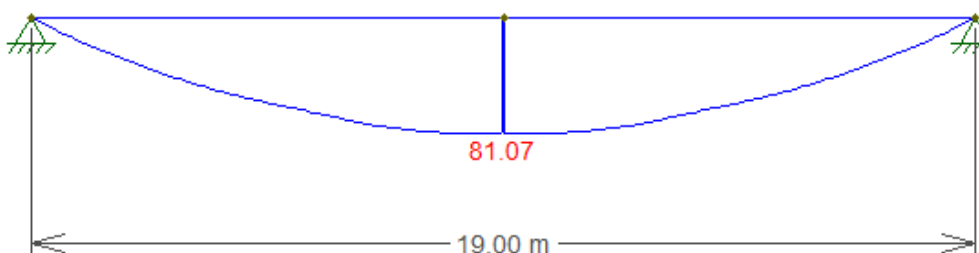

Figura 110 – Carregamento do veículo I-63



Figura 111 – Linha de influência para o momento fletor veículo I-63

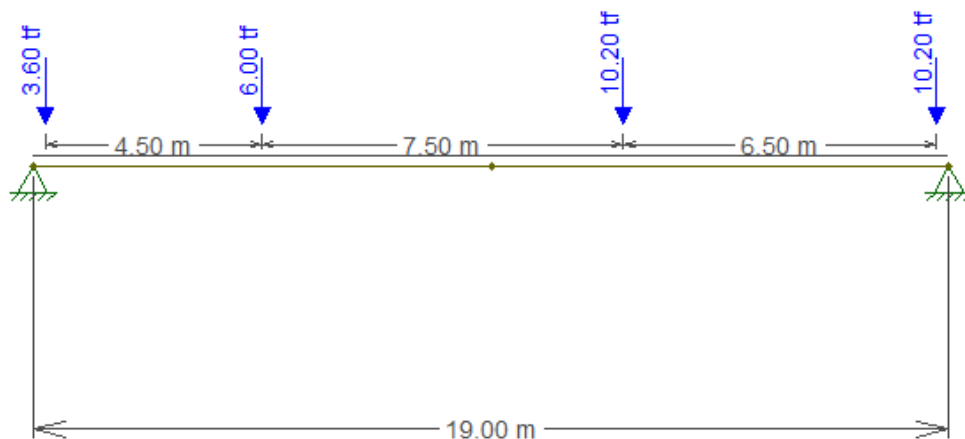

Figura 112 – Envoltória de momento fletor veículo I-63

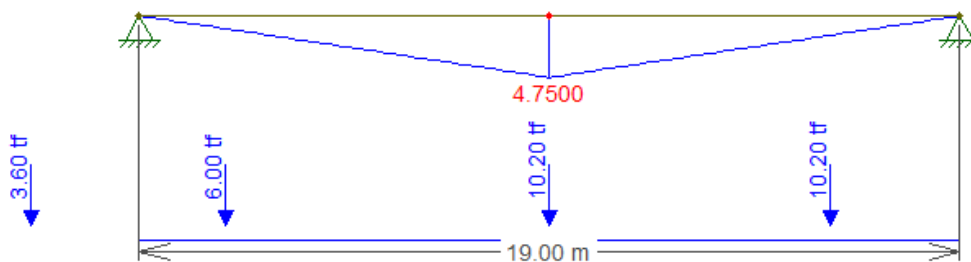

Figura 113 – Veículo I-64

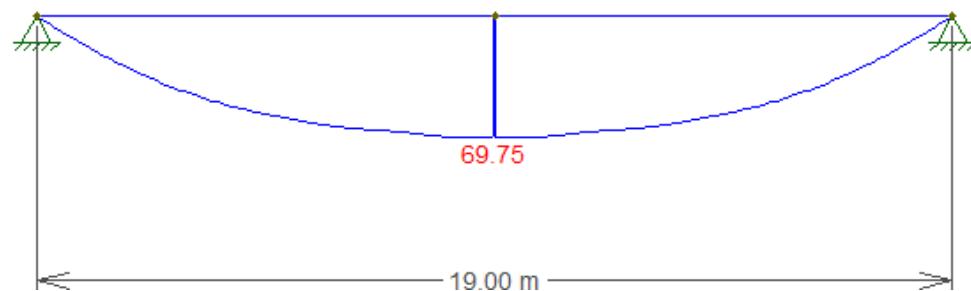

Figura 114 – Carregamento do veículo I-64



Figura 115 – Linha de influência para o momento fletor veículo I-64

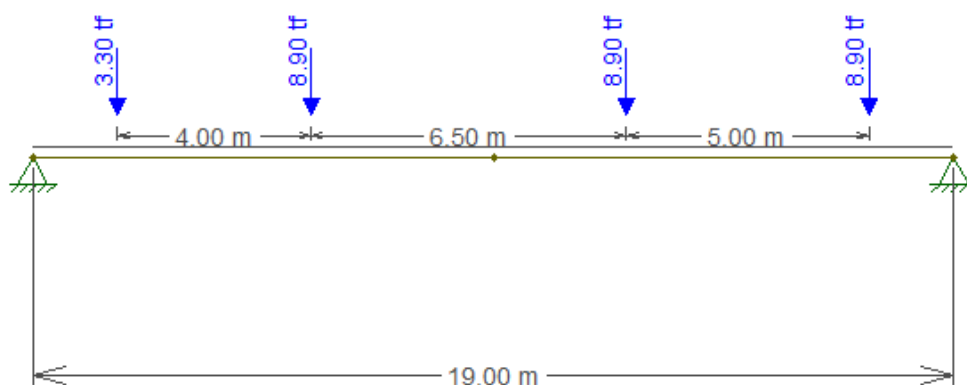

Figura 116 – Envoltória de momento fletor veículo I-64

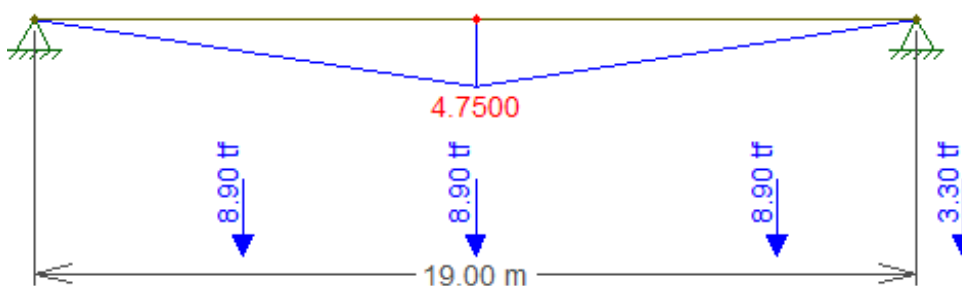

Figura 117 – Veículo I-64A

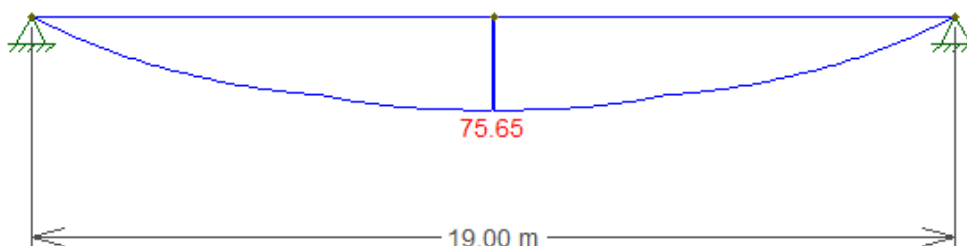

Figura 118 – Carregamento do veículo I-64A



Figura 119 – Linha de influência para o momento fletor veículo I-64A

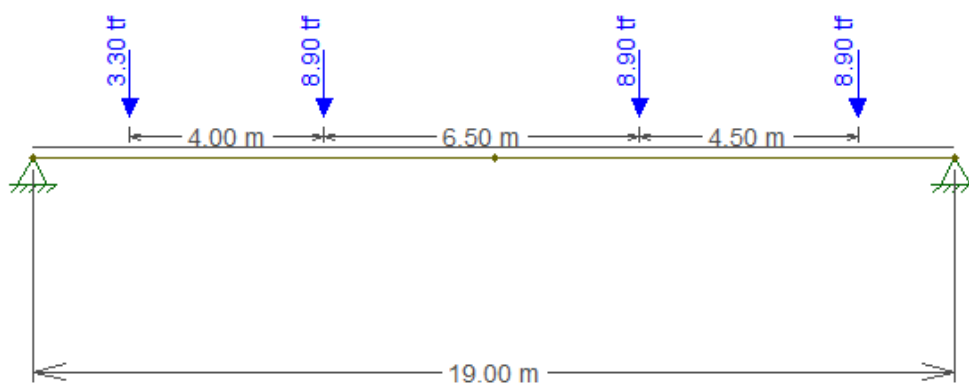

Figura 120 – Envoltória de momento fletor veículo I-64A

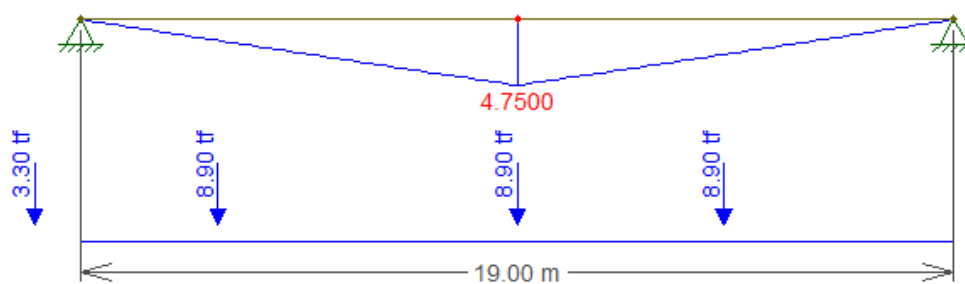

Figura 121 – Veículo II-6

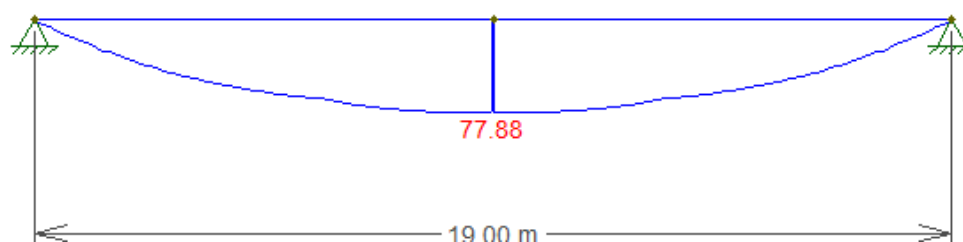

Figura 122 – Carregamento do veículo II-6



Figura 123 – Linha de influência para o momento fletor veículo II-6

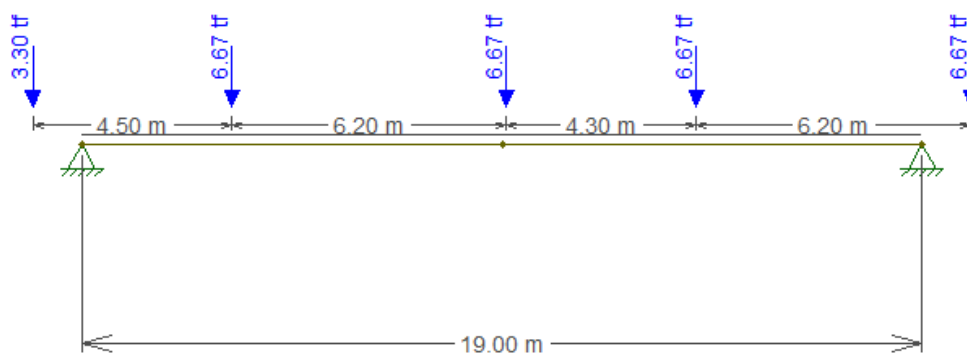

Figura 124 – Envoltória de momento fletor veículo II-6

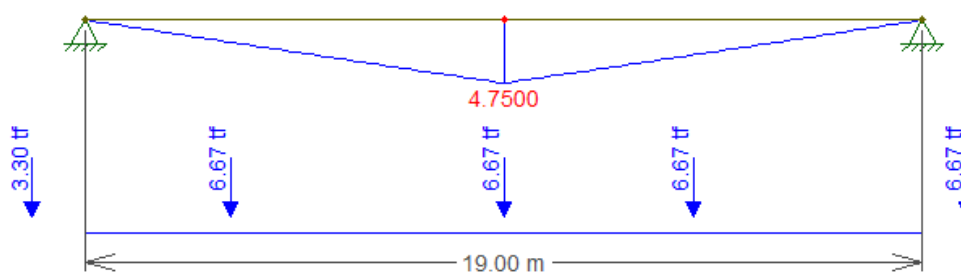

Figura 125 – Veículo II-18

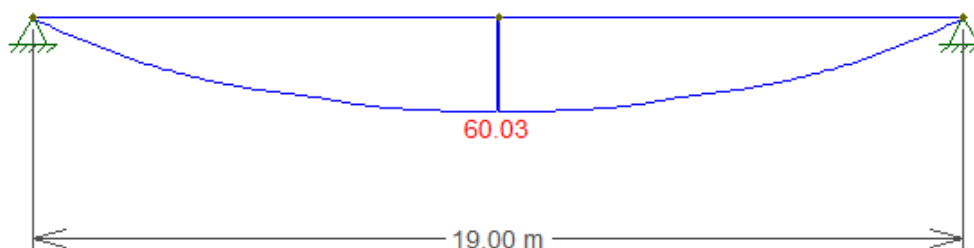

Figura 126 – Carregamento do veículo II-18



Figura 127 – Linha de influência para o momento fletor veículo II-18

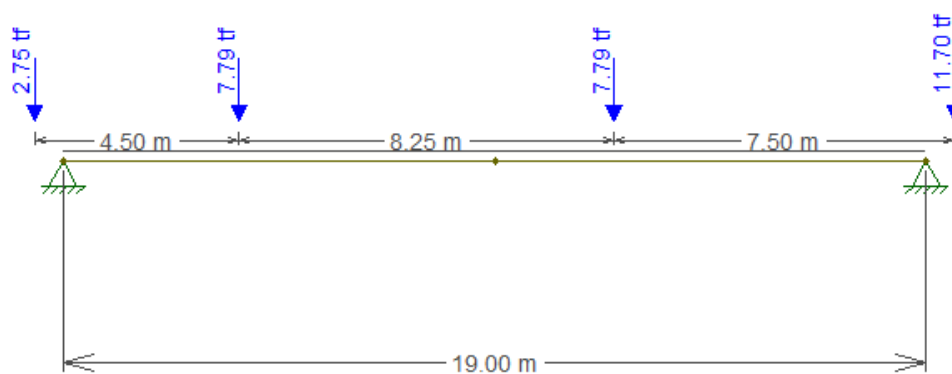

Figura 128 – Envoltória de momento fletor veículo II-18

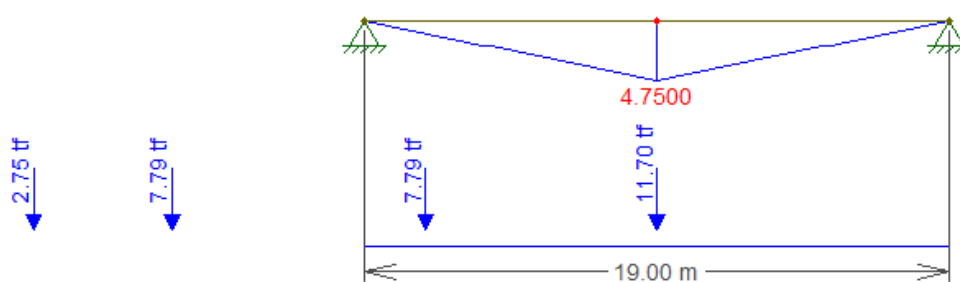

Figura 129 – Veículo II-19

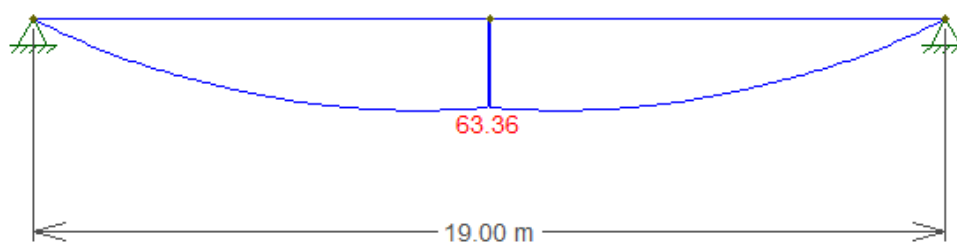

Figura 130 – Carregamento do veículo II-19



Figura 131 – Linha de influência para o momento fletor veículo II-19

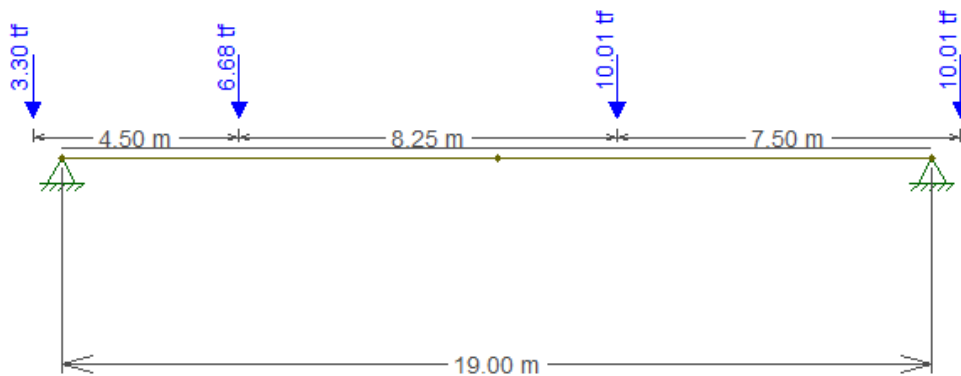

Figura 132 – Envoltória de momento fletor veículo II-19

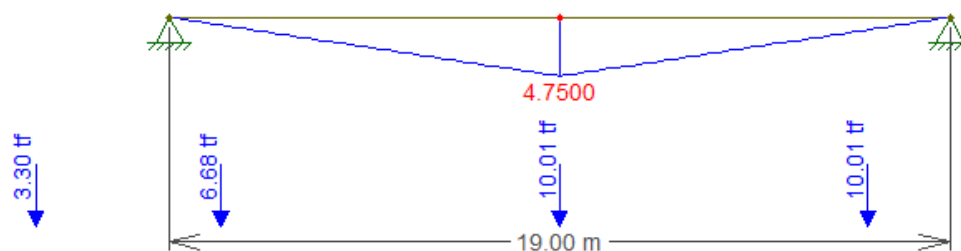

Figura 133 – Veículo III-2

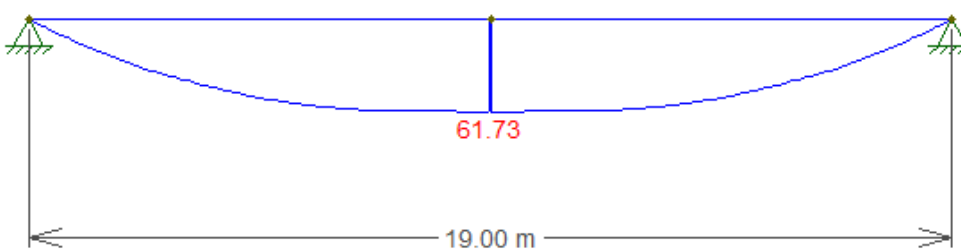

Figura 134 – Carregamento do veículos III-1, III-2



Figura 135 – Linha de influência para o momento fletor veículos III-1, III-2

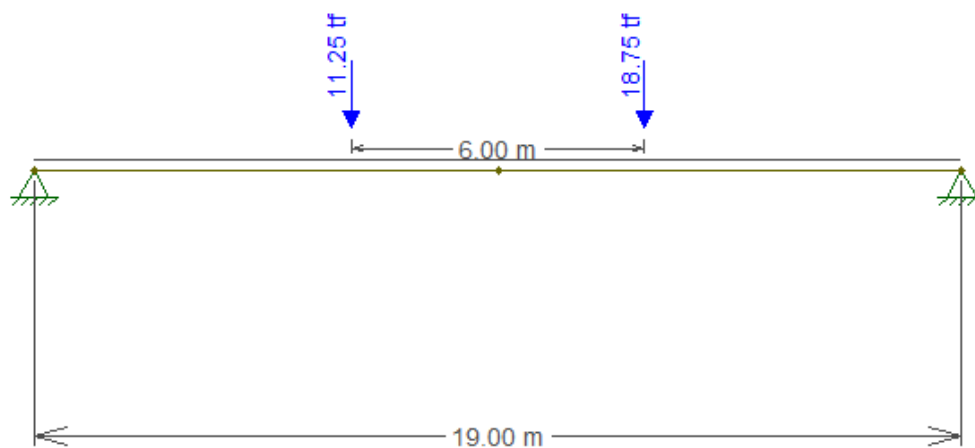

Figura 136 – Envoltória de momento fletor veículos III-1, III-2

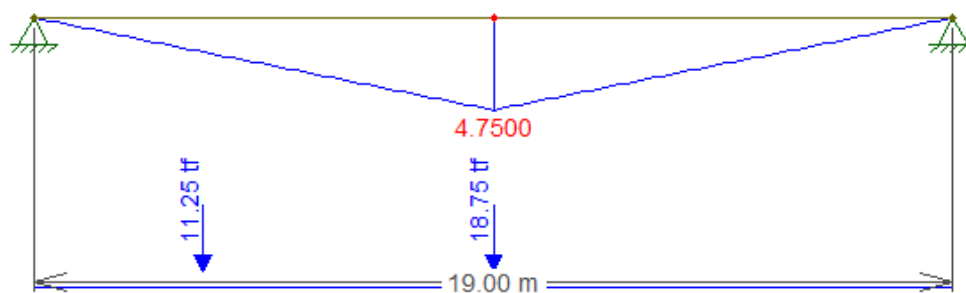

Figura 137 – Veículo III-3

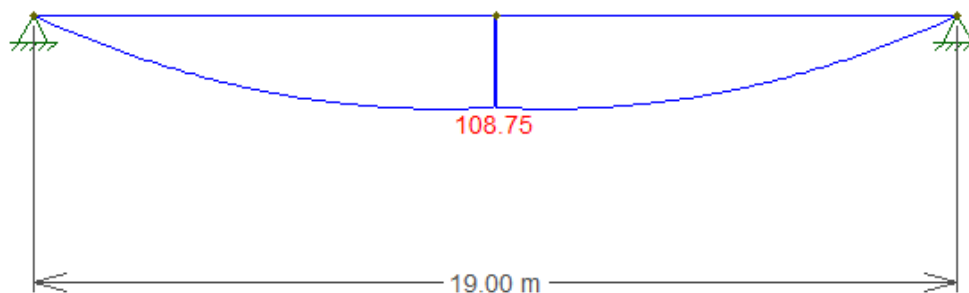

Figura 138 – Carregamento do veículos III-3, III-4, III-5, III-15, III-16 e III-19



Figura 139 – Linha de influência para o momento fletor veículos III-3, III-4, III-5, III-15, III-16 e III-19

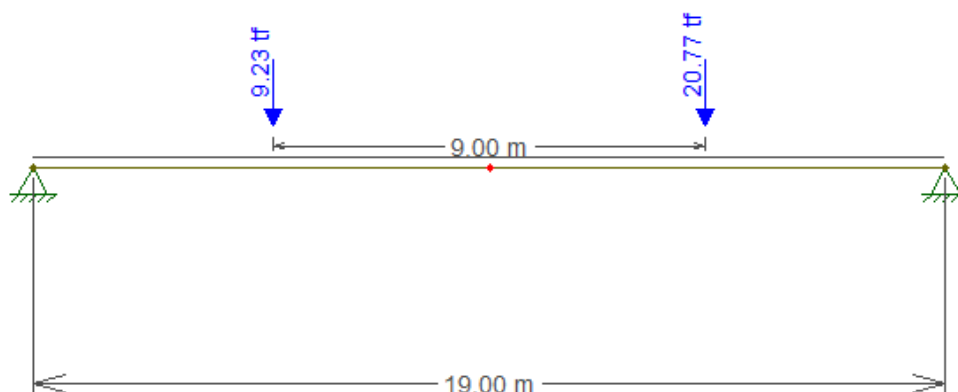
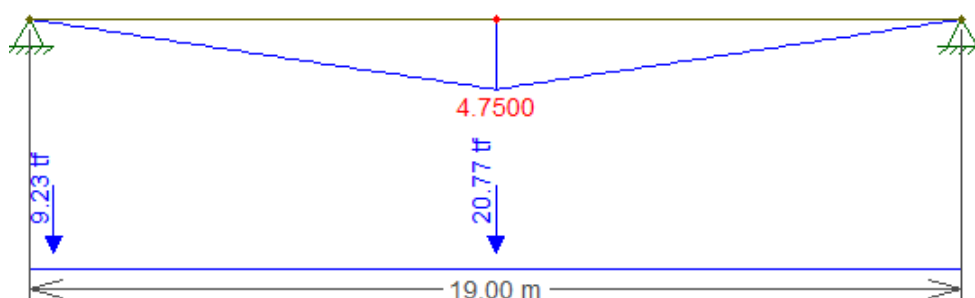
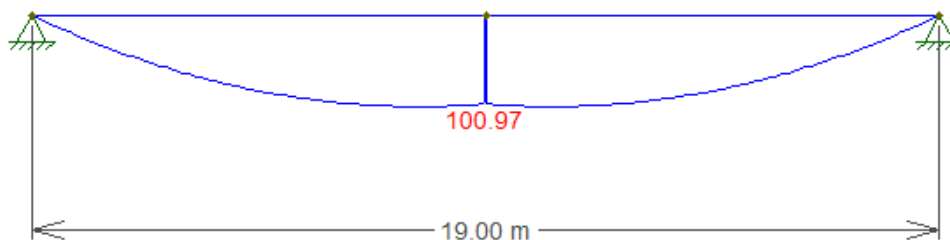

Figura 140 – Envoltória de momento fletor veículos III-3, III-4, III-5, III-15, III-16 e III-19